

Panasonic

SCROLL COMPRESSORS

Code : 809 125 88

Model : C-SCN903H8T

PANASONIC APPLIANCES COMPRESSOR (DALIAN) CO., LTD.

Rev.2020-3

Scroll Compressor

Model C-SCN903H8T

Electrical 380-415 Volts 3 Phase 50Hz

Refrigerant R407C

Nominal Performance at ARI

Power Source	<u>50Hz-380V</u>
Capacity (W)	<u>34900</u>
Power (W)	<u>11300</u>
Current (A)	<u>18.9</u>
COP (W/W)	<u>3.09</u>
Mass Flow (kg/h)	<u>835</u>

Rating Conditions (MID Point)

Condensing Temperature(°C)	<u>54.4</u>
Evaporating Temperature(°C)	<u>7.2</u>
Return Gas temperature(°C)	<u>18.3</u>
Liquid Temperature(°C)	<u>43.8</u>
Ambient Temperature(°C)	<u>35</u>

Motor

	50Hz
Voltage Range(V)	<u>342-456</u>
RLA (A)	<u>21.6</u>
MCC (A)	<u>30.2</u>
LRA (A)	<u>96</u>
RPM (min ⁻¹)	<u>2900</u>

Compressor

Maximum Discharge Temp(°C)	<u>135</u>
Displacement (cm ³ /rev)	<u>205.4</u>
Weight (with oil kg)	<u>70.5</u>

Oil

Oil Type	<u>FV68S</u>
Initial Charge (ml)	<u>2800</u>
Re-charge (ml)	<u>2600</u>

Electrical Components

Motor Protector Type	<u>Internal</u>
Run Capacitor Rating (MFD/Volts)	<u>n/a</u>

Nominal performance values +/-5% with 1 hr run-in.

Ratings with air over compressor.

Specifications subject to change without notice.

PERFORMANCE DATA

Compressor Model(Code)	C-SCN903H8T (809 125 88)
Power Source	3PH 50Hz 380-415V
Suction Gas Superheat(K)	9
Sub Cooling(K)	8.3
Compressor Cooling	Natural Cooling
Refrigerant	R407C

CAPACITY(W)

Condensing Temperature(°C)	Evaporating Temperature(°C)							
	-15	-10	-6.7	0	4.4	7.2	10	12
35.0	19,690	24,030	27,410	35,810	42,680	47,720	53,360	57,790
40.5	18,020	22,000	25,100	32,800	39,100	43,720	48,890	52,960
45.0	16,750	20,450	23,330	30,500	36,360	40,660	45,480	49,260
50.0	15,430	18,840	21,500	28,110	33,520	37,490	41,930	45,430
54.4		17,530	20,010	26,160	31,200	34,900	39,040	42,290
60.0			18,260	23,880	28,490	31,870	35,650	38,630
65.0				22,040	26,290	29,420	32,910	35,660

POWER(W)

Condensing Temperature(°C)	Evaporating Temperature(°C)							
	-15	-10	-6.7	0	4.4	7.2	10	12
35.0	6,930	7,120	7,220	7,350	7,380	7,380	7,360	7,330
40.5	7,840	8,020	8,120	8,250	8,280	8,290	8,280	8,260
45.0	8,720	8,880	8,970	9,100	9,140	9,150	9,160	9,150
50.0	9,820	9,960	10,040	10,160	10,210	10,240	10,260	10,260
54.4		11,020	11,080	11,200	11,260	11,300	11,330	11,360
60.0			12,560	12,660	12,740	12,800	12,860	12,900
65.0				14,100	14,200	14,270	14,360	14,430

CURRENT(A)

Condensing Temperature(°C)	Evaporating Temperature(°C)							
	-15	-10	-6.7	0	4.4	7.2	10	12
35.0	12.0	12.4	12.6	12.8	12.9	12.9	12.8	12.8
40.5	13.5	13.8	14.0	14.2	14.3	14.3	14.3	14.2
45.0	14.9	15.2	15.3	15.6	15.6	15.6	15.6	15.6
50.0	16.7	16.9	17.0	17.2	17.3	17.3	17.3	17.3
54.4		18.6	18.6	18.7	18.8	18.9	19.0	19.0
60.0			20.9	20.9	21.0	21.1	21.3	21.4
65.0				23.1	23.2	23.3	23.5	23.6

NOTE:

- * The performance values subject to change without notice.
- * The performance values are based on MID point method.

Compressor Model(Code)
Power Source

C-SCN903H8T (809 125 88)
3PH 50Hz 380-415V

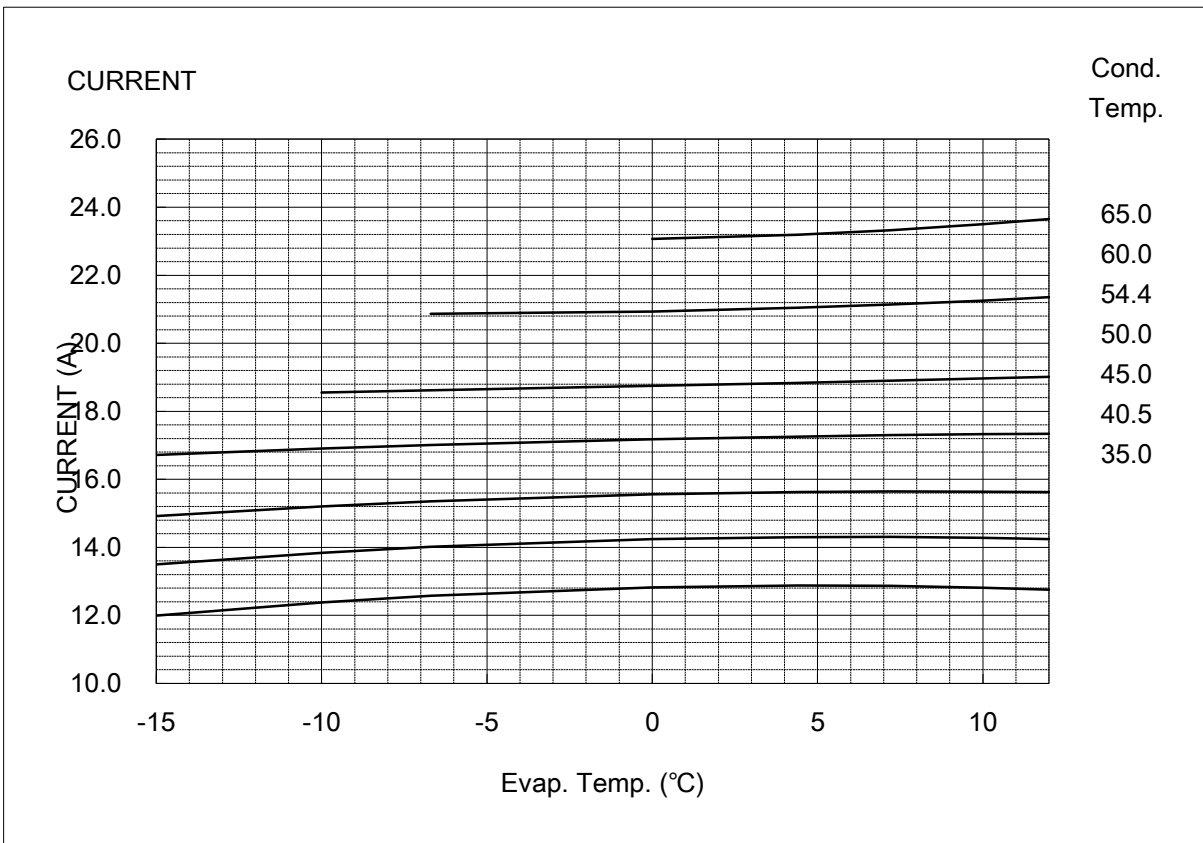
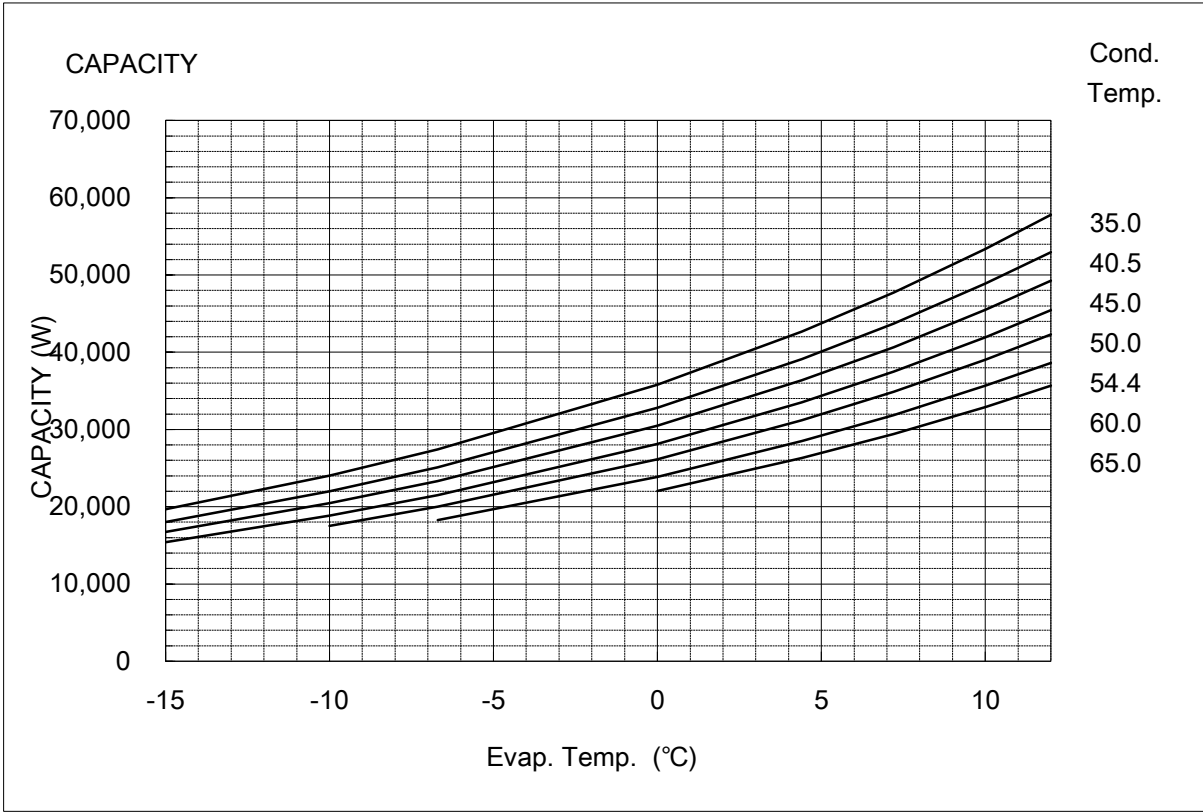

COEFFICIENTS OF PERFORMANCE CURVES

Compressor Model **C-SCN903H8T (809 125 88)**
 Power Source **3PH 50Hz 380-415V**
 Suction Gas Superheat (K) **9**
 Sub Cooling (K) **8.3**
 Compressor Cooling **Natural Cooling**
 Refrigerant **R407C**

$$X=C1+C2*(S)+C3*D+C4*(S^2)+C5*(S*D)+C6*(D^2)+C7*(S^3)+C8*(D*S^2)+C9*(S*D^2) +C10*(D^3)$$

X—CAPACITY(W) OR POWER(W) OR CURRENT(A) OR FLOW(kg/h)

S—EVAPORATING TEMP, °C

D—CONDENSING TEMP, °C

<u>380V-50Hz</u>	CAPACITY (W)	POWER (W)	CURRENT (A)
C1	6.025574E+04	5.368588E+03	9.059758E+00
C2	2.451302E+03	1.372821E+01	2.449943E-02
C3	-8.283006E+02	-3.385155E+01	-1.759710E-02
C4	4.256880E+01	-2.996130E+00	-7.324320E-03
C5	-3.466004E+01	-2.783444E-01	-2.297702E-04
C6	3.701802E+00	2.590459E+00	3.592793E-03
C7	3.175990E-01	4.044492E-03	1.061394E-05
C8	-3.899505E-01	5.141902E-02	1.377047E-04
C9	1.615954E-01	5.854275E-03	2.941146E-06
C10	-2.701611E-08	-3.076689E-08	-5.415134E-11

Note: The polynomial coefficients subject to change without notice.

WIRING & MOUNTING SKETCH

WIRING DIAGRAM C-SC Series 3phase B8

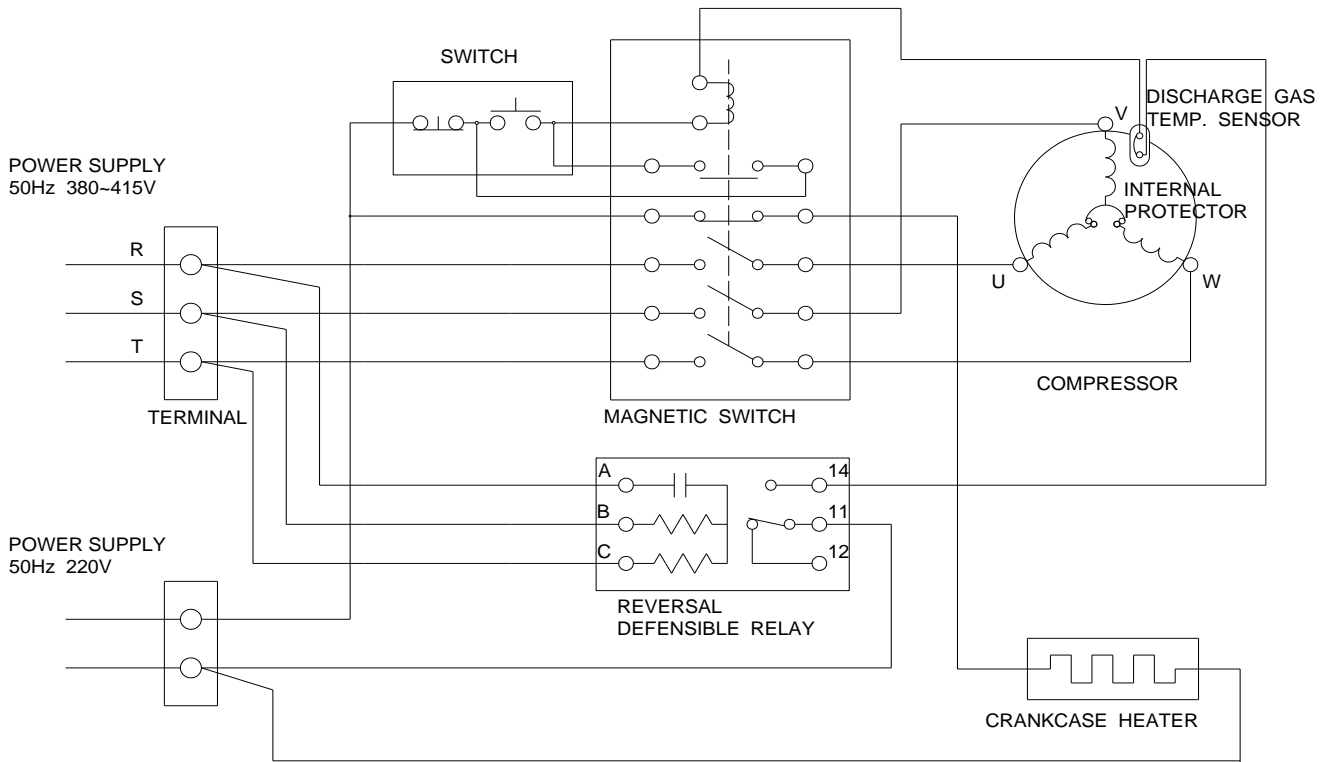

MOUNTING SKETCH

