

SC15FT Tropical Compressor R134a 220-240V 50/60Hz

General

Code number	104G8506
Approvals	EN 60335-2-34
Compressors on pallet	80

Application

Application	LBP			
Frequency	Hz	50	60	
Evaporating temperature	°C	-35 to -5		-35 to -5
Voltage range	V	187 - 254		198 - 254
Max. condensing temperature continuous (short)	°C	60 (70)		60 (70)
Max. winding temperature continuous (short)	°C	125 (135)		125 (135)

Cooling requirements

Frequency	Hz	50			60		
Application		LBP	MBP	HBP	LBP	MBP	HBP
32°C		F ₁	-	-	F ₁	-	-
38°C		F ₁	-	-	F ₁	-	-
43°C		F ₂	-	-	F ₂	-	-

Remarks on application:
F₁ at 43°C ambient temperature possible at 220V nominal (187-242V)

Motor

Motor type	RSIR/CSIR		
LRA (rated after 4 sec. UL984), HST LST	A	14.8	15.5
Cut in Current, HST LST	A	14.8	19.9
Resistance, main start winding (25°C)	Ω	5.0	13.7

Design

Displacement	cm ³	15.28
Oil quantity (type)	cm ³	550 (polyolester)
Maximum refrigerant charge	g	1300
Free gas volume in compressor	cm ³	1410
Weight without electrical equipment	kg	13.1

Dimensions

Height	mm	A	209
		B	203
		B1	183
		B2	100
Suction connector	location/I.D. mm angle	C	10.2 37°
	material comment	Copper Rubber plug	
Process connector	location/I.D. mm angle	D	6.5 37°
	material comment	Copper Rubber plug	
Discharge connector	location/I.D. mm angle	E	6.5 37°
	material comment	Copper Rubber plug	
Oil cooler connector	location/I.D. mm angle	F	-
	material comment	-	
Connector tolerance	I.D. mm	±0.09	
Remarks:			

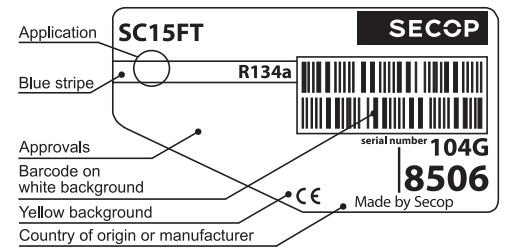

- S = Static cooling normally sufficient
- O = Oil cooling
- F₁ = Fan cooling 1.5 m/s
(compressor compartment temperature equal to ambient temperature)
- F₂ = Fan cooling 3.0 m/s necessary
- SG = Suction gas cooling normally sufficient
- = not applicable in this area

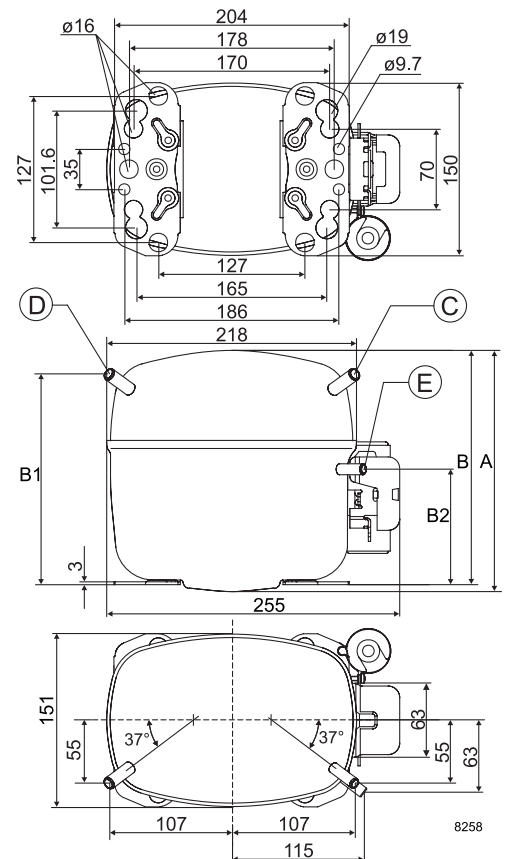

EN 12900 Household (CECOMAF) 220V, 50Hz, fan cooling F₁

Evap. temp. in °C	-45	-40	-35	-30	-25	-23.3	-20	-15	-10	-6.7	-5	0	5	7.2	10	15	20
Capacity in W			126	197	280	311	376	489	620	718	772						
Power cons. in W			223	267	311	326	356	403	451	483	500						
Current cons. in A			2.22	2.31	2.42	2.46	2.54	2.69	2.86	2.98	3.05						
COP in W/W			0.56	0.74	0.90	0.95	1.06	1.21	1.38	1.49	1.54						

EN 12900 Household (CECOMAF) 220V, 60Hz, fan cooling F₁

Evap. temp. in °C	-45	-40	-35	-30	-25	-23.3	-20	-15	-10	-6.7	-5	0	5	7.2	10	15	20
Capacity in W			154	235	330	365	441	571	724	840	904						
Power cons. in W			231	294	356	377	418	478	537	576	596						
Current cons. in A			1.87	2.07	2.27	2.34	2.48	2.70	2.93	3.08	3.16						
COP in W/W			0.66	0.80	0.92	0.97	1.05	1.19	1.35	1.46	1.52						

ASHRAE LBP 220V, 50Hz, fan cooling F₁

Evap. temp. in °C	-45	-40	-35	-30	-25	-23.3	-20	-15	-10	-6.7	-5	0	5	7.2	10	15	20
Capacity in W			157	245	347	385	466	606	769	890	958						
Power cons. in W			224	267	311	326	356	402	450	482	499						
Current cons. in A			2.22	2.31	2.42	2.46	2.54	2.69	2.86	2.98	3.04						
COP in W/W			0.70	0.92	1.12	1.18	1.31	1.51	1.71	1.85	1.92						

ASHRAE LBP 220V, 60Hz, fan cooling F₁

Evap. temp. in °C	-45	-40	-35	-30	-25	-23.3	-20	-15	-10	-6.7	-5	0	5	7.2	10	15	20
Capacity in W			192	292	409	452	546	708	899	1042	1123						
Power cons. in W			232	295	357	377	417	477	536	574	594						
Current cons. in A			1.88	2.07	2.27	2.34	2.48	2.69	2.92	3.07	3.16						
COP in W/W			0.83	0.99	1.15	1.20	1.31	1.48	1.68	1.81	1.89						

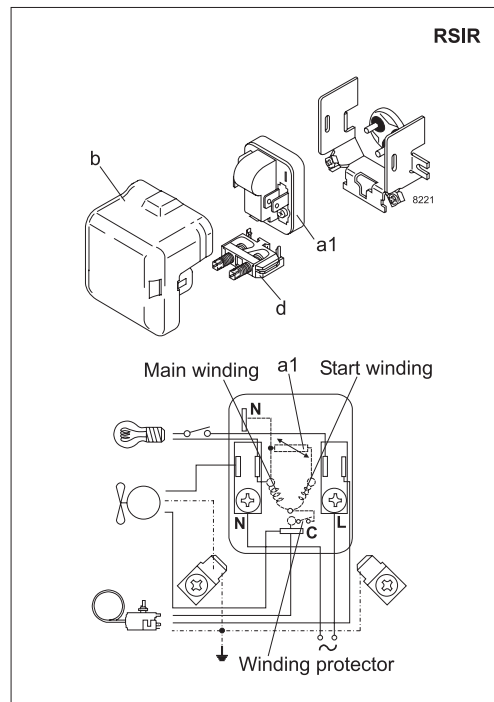
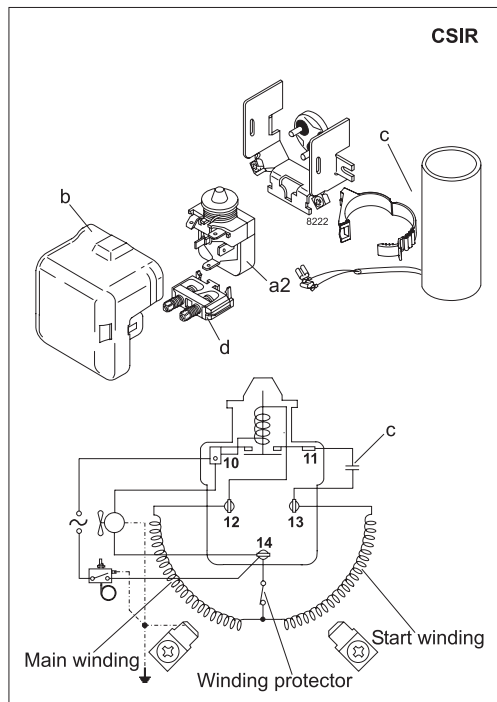

Accessories for	SC15FT	Figure	Code number
PTC starting device	6.3 mm spade connectors	a1	103N0011
	4.8 mm spade connectors		-
Starting relay	6.3 mm spade connectors	a2	117U6005
Cover		b	103N2009
Start. capacitor 80 µF	6.3 mm spade connectors	c	117U5017
Cord relief		d	103N1004
Protection screen for PTC		g	-

Test conditions	EN 12900/CECOMAF	ASHRAE LBP
Condensing temperature	55°C	55°C
Ambient temperature	32°C	32°C
Suction gas temperature	32°C	32°C
Liquid temperature	55°C	32°C

Mounting accessories		Code number
Bolt joint for one comp.	Ø: 16 mm	118-1917
Bolt joint in quantities	Ø: 16 mm	118-1918
Snap-on in quantities	Ø: 16 mm	118-1919

Secop accepts no responsibility for possible errors in catalogs, brochures, and other printed material. Secop reserves the right to alter its products without notice. This also applies to products already on order provided that such alterations can be made without consequential changes being necessary to specifications already agreed. All trademarks in this material are the property of the respective companies. Secop and the Secop logotype are trademarks of Secop GmbH. All rights reserved. www.secop.com