

Technical Data Sheet

Compressor model **MPT14RA**
 Voltage **220-240V 50Hz ~1**
 Refrigerant **R404A**

APPLICATION

Application High Back Pressure
 Refrigerant R404A
 Evaporating Temp. -15,0 °C to 10,0 °C
 Expansion Capillar/Valve
 Comp. Cooling Fan cooled
 Max. ambient temp. 43,0 °C

COMPRESSOR

Displacement 14,32 cm³
 Diameter 29,37 mm
 Stroke 21,13 mm
 Net Weight 12,25 Kg
 Oil type ISO VG 32 ESTER
 Oil charge 400 cm³

MOTOR

Nominal Power 1/2 hp
 Voltage/Frequency 220-240V 50Hz
 Voltage range 198-255 V
 Type CSR
 Phase number 1 PH
 Locked Rotor Amps (LRA) 21,00 A
 Max. Cont. Current (MCC) 6,50 A
 Main W. resist. at 25°C 4,50 Ω
 Start W. resist. at 25°C 5,75 Ω

NOMINAL PERFORMANCE

	ASHRAE	CECOMAF
Cooling Capacity	1.900 kCal/h	1.750 W
COP	2,20 W/W	1,78 W/W
EER	1,89 kCal/Wh	1,54 kCal/Wh
Input Power	1.004 W	984 W
Current	4,61 A	4,52 A

APPROVALS



TEST CYCLE CONDITIONS

	ASHRAE HBP (D)	CECOMAF HBP (C)
Evaporating temp. (T _e)	7,2 °C	5,0 °C
Condensing temp. (T _c)	55,0 °C	55,0 °C
Liquid temp. (T _{liq.})	46,0 °C	55,0 °C
Ambient temp. (T _{amb.})	35,0 °C	32,0 °C
Suction temp. (T _{suction})	35,0 °C	32,0 °C
Voltage/Frequency	220 V 50 Hz	220 V 50 Hz

ELECTRICAL COMPONENTS

Starting capacitor	64- 77 μF 330 V		
Run capacitor	25 μF 420 V		
Relay	Option 1		
Reference	2014 166. + NTC15Ω		
Pick-Up	11,00 A		
Drop-Out	9,35 A		
Protector	Option 1	Option 2	
Reference	MRA38134	T0348	
Current	15,80 A	15,40 A	
Time check	7,5-14 seg	7,5-14 seg	
Disc temp. (Open/Close)	105,00 / 52,00 °C	105,00 / 52,00 °C	

ASHRAE

Tc °C	Te °C	Cooling Capacity kCal/h	Consumption W	Current A	COP W/W	EER kCal/Wh
40	-15	1.026	665	3,06	1,79	1,54
40	-10	1.267	720	3,32	2,05	1,76
40	-5	1.540	775	3,57	2,31	1,99
40	0	1.845	829	3,82	2,59	2,23
40	5	2.182	882	4,06	2,88	2,47
40	7,2	2.341	905	4,16	3,01	2,59
40	10	2.552	934	4,30	3,18	2,73

45	-15	947	683	3,14	1,61	1,39
45	-10	1.172	742	3,41	1,84	1,58
45	-5	1.430	799	3,68	2,08	1,79
45	0	1.720	857	3,94	2,33	2,01
45	5	2.042	913	4,20	2,60	2,24
45	7,2	2.194	938	4,31	2,72	2,34
45	10	2.396	969	4,45	2,88	2,47

50	-15	868	701	3,23	1,44	1,24
50	-10	1.078	763	3,51	1,64	1,41
50	-5	1.320	824	3,80	1,86	1,60
50	0	1.595	885	4,07	2,10	1,80
50	5	1.902	945	4,34	2,34	2,01
50	7,2	2.047	971	4,46	2,45	2,11
50	10	2.241	1.004	4,61	2,60	2,23

55	-15	789	719	3,31	1,28	1,10
55	-10	984	784	3,61	1,46	1,25
55	-5	1.211	849	3,91	1,66	1,43
55	0	1.470	913	4,20	1,87	1,61
55	5	1.762	976	4,49	2,10	1,80
55	7,2	1.900	1.004	4,61	2,20	1,89
55	10	2.085	1.039	4,77	2,33	2,01

60	-15	710	737	3,39	1,12	0,96
60	-10	889	806	3,71	1,28	1,10
60	-5	1.101	874	4,02	1,47	1,26
60	0	1.345	941	4,33	1,66	1,43
60	5	1.621	1.008	4,63	1,87	1,61
60	7,2	1.753	1.037	4,76	1,97	1,69
60	10	1.930	1.074	4,92	2,09	1,80

CECOMAF

Tc °C	Te °C	Cooling Capacity W	Consumption W	Current A	COP W/W	EER kCal/Wh
40	-15	1.075	669	3,08	1,61	1,39
40	-10	1.331	725	3,34	1,84	1,59
40	-5	1.617	780	3,59	2,07	1,79
40	0	1.935	834	3,84	2,32	2,00
40	5	2.283	888	4,09	2,57	2,22
40	7,2	2.446	912	4,20	2,68	2,32
40	10	2.663	942	4,33	2,83	2,44

45	-15	979	687	3,16	1,43	1,23
45	-10	1.215	746	3,44	1,63	1,41
45	-5	1.481	805	3,71	1,84	1,59
45	0	1.778	863	3,97	2,06	1,78
45	5	2.106	920	4,23	2,29	1,98
45	7,2	2.260	945	4,35	2,39	2,07
45	10	2.464	977	4,49	2,52	2,18

50	-15	884	705	3,25	1,25	1,08
50	-10	1.099	768	3,54	1,43	1,24
50	-5	1.344	830	3,82	1,62	1,40
50	0	1.621	891	4,10	1,82	1,57
50	5	1.928	952	4,38	2,03	1,75
50	7,2	2.073	978	4,50	2,12	1,83
50	10	2.266	1.012	4,65	2,24	1,93

55	-15	789	723	3,33	1,09	0,94
55	-10	983	789	3,63	1,25	1,08
55	-5	1.208	855	3,93	1,41	1,22
55	0	1.464	919	4,23	1,59	1,38
55	5	1.750	984	4,52	1,78	1,54
55	7,2	1.886	1.012	4,64	1,86	1,61
55	10	2.068	1.047	4,80	1,97	1,71

60	-15	694	741	3,41	0,94	0,81
60	-10	867	811	3,73	1,07	0,92
60	-5	1.071	879	4,05	1,22	1,05
60	0	1.307	948	4,36	1,38	1,19
60	5	1.573	1.015	4,66	1,55	1,34
60	7,2	1.700	1.045	4,79	1,63	1,41
60	10	1.870	1.082	4,96	1,73	1,49

EN12900

X	Cooling Capacity (W)	Consumption (W)	Current (A)	Mass Flow (kg/h)
1	3.198,2336033645	625,4757856499	2,9040308312	59,970790248955
2	100,6583652073	5,8986636105	0,0284352343	2,0399628841731
3	-32,9029925749	5,8527884589	0,0263895496	-0,16718314570882
4	0,5844161735	0,0028317983	-0,0000414355	0,030625240676891
5	-0,8953568390	0,1425238691	0,0006099005	0,0010188842479041

Equation	$x_1 + x_2Te + x_3Tc + x_4Te^2 + x_5TeTc$
----------	---

Technical Data Sheet

COMPRESSOR DIMENSIONS

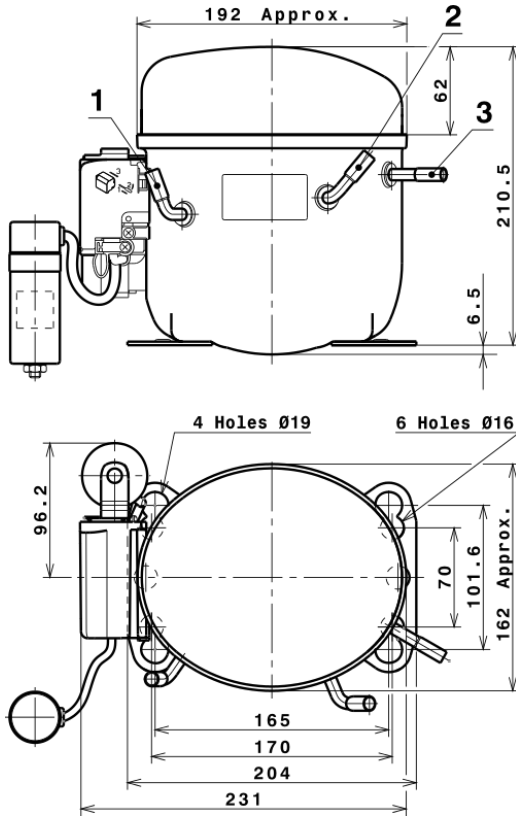

	DESIGNATION	INTERNAL DIAM.
1	Suction	8,1 mm
2	Service	8,1 mm
3	Discharge	6,5 mm

WIRING DIAGRAMS AND ELECTRICAL ASSEMBLY

CSR CONNECTION (CURRENT RELAY + NTC) (L, P ranges)

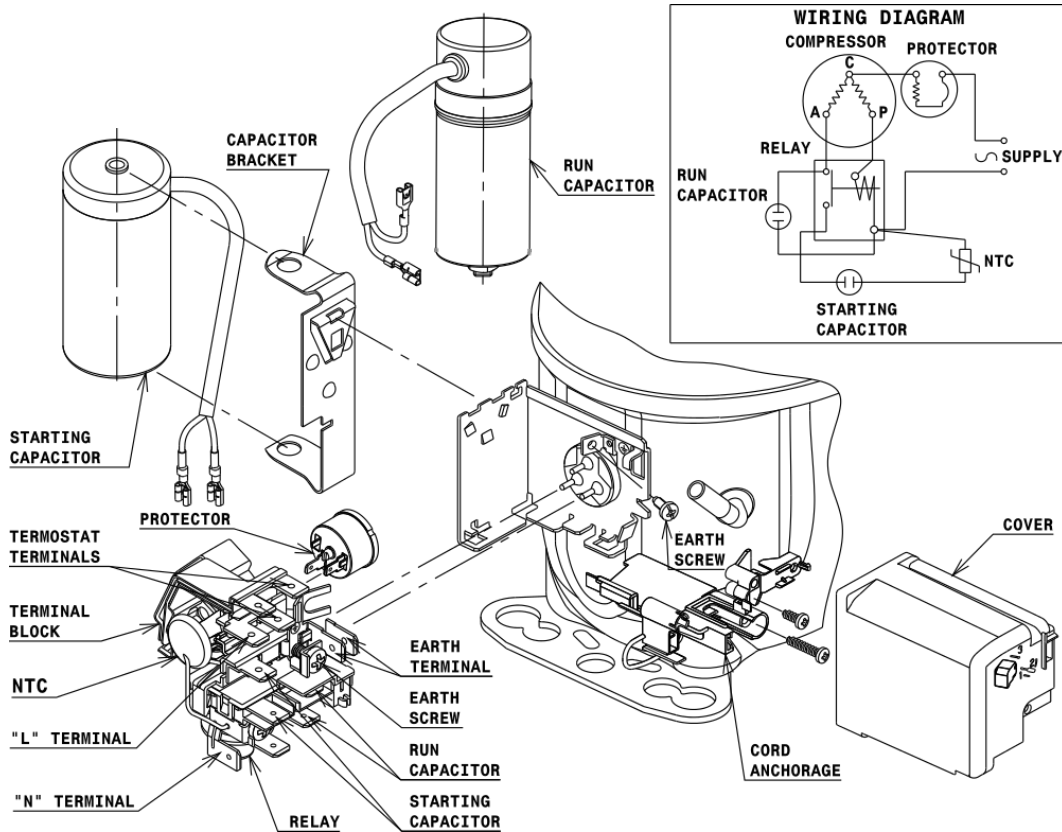

FIXINGS



SILENT BLOCKS (MOUNTING ACCESSORIES)

STANDARD

$\varnothing 16$ holes (170x70 net)



AMERICAN FEET

$\varnothing 19$ holes (165x101.6 net)



SNAP-ON

$\varnothing 16$ holes (170x70 net)



SOA

SOA R404A HBP

